

KOHLER®

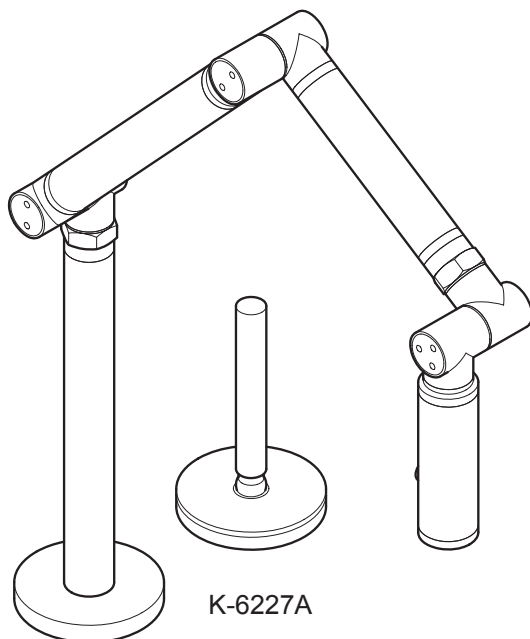

Karbon™ Kitchen Sink Tap Installation and User Guide

IMPORTANT

INSTALLER:

This product manual is the property of the customer and must be retained with the product for maintenance and operational purposes.

IMPORTANT INFORMATION

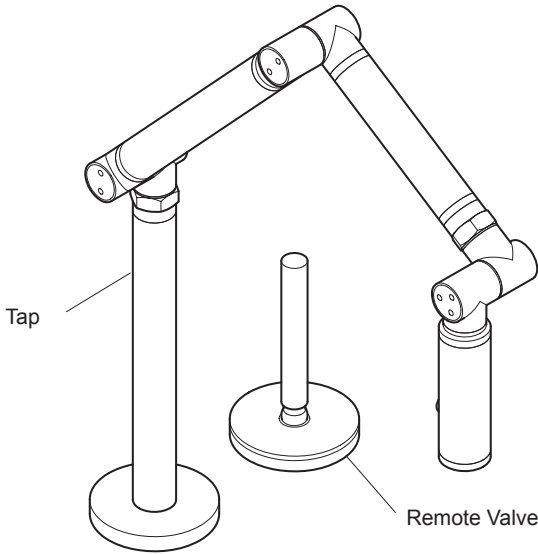

Due to the non-standard diameter of the remote valve (51 mm), the remote valve cannot be installed through a standard 35 mm tap hole in a sink. Choose a sink without tap holes then install the tap and remote valve through the countertop. Refer to the countertop manufacturer for drilling of the holes.

1. Make sure that you follow all the local plumbing and building regulations in operation.
2. For new installations, install the tap in the sink before installing the sink.
3. Before installation, unpack the tap and inspect for damage.

SPECIFICATION

Plumbing Connections

G ½" Compression Fitting

Hot (H) and Cold (C) inlets must be connected to the correct inlet supplies.

Applicable Standards

ASME A112.18.1-2005/CSA B125.1-05; AS/NZS 6400:2005; AS/NZS 3718:2005; AS/NZS 4020:2005

Recommended Operating Pressures: 140 to 860 kPa (20 to 125 psi).

Rated Operating Temperatures: 5° to 71° C (40° to 160° F).

Tested Hydrostatic Burst Pressure: 3450 kPa (500 psi).

INSTALLATION

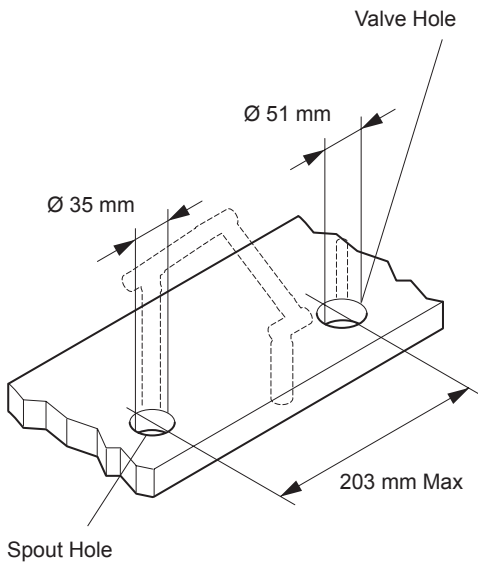

1. Locate the remote valve within 203 mm of the spout. Refer to the countertop manufacturer for drilling of the holes.

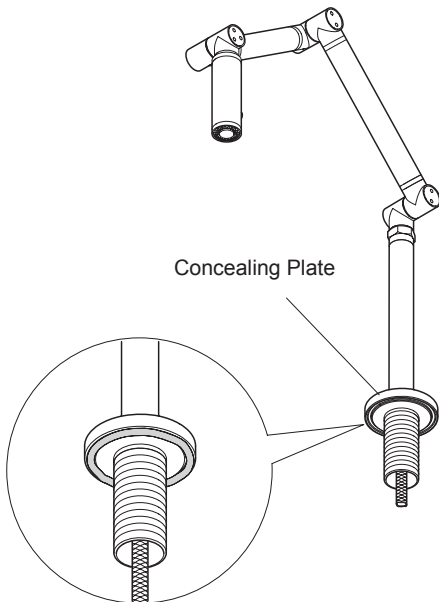

2. Apply silicone sealant to the underside of the concealing plate.

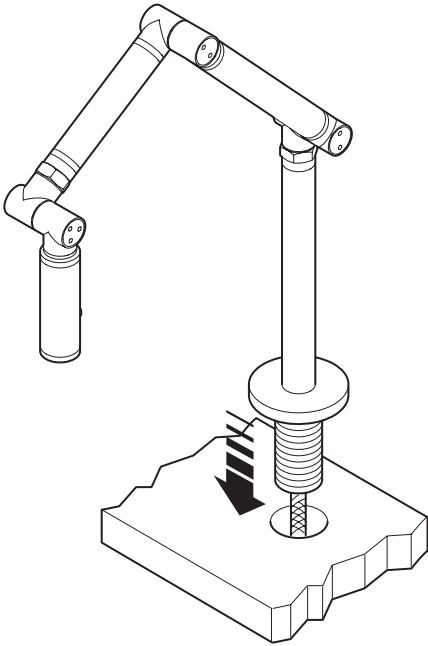

3. Insert the tap through the mounting hole.

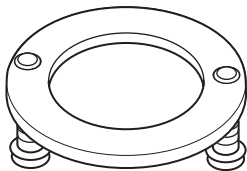

4. Partially thread the screws into the ring.

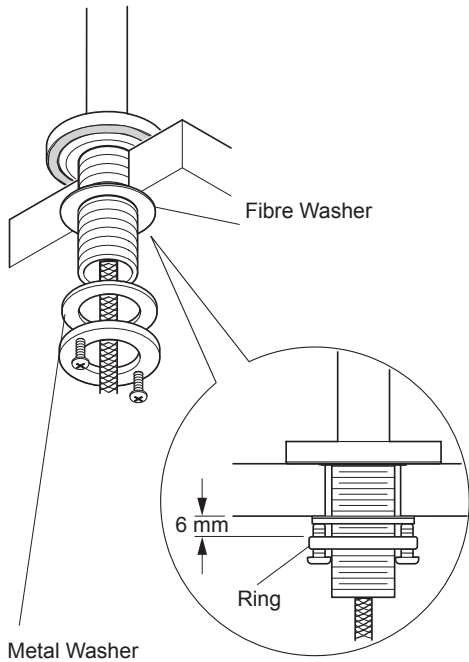

5. Fit the fibre and metal washers onto the threaded shank

Install the ring leaving approximately 6 mm between the ring and the countertop.

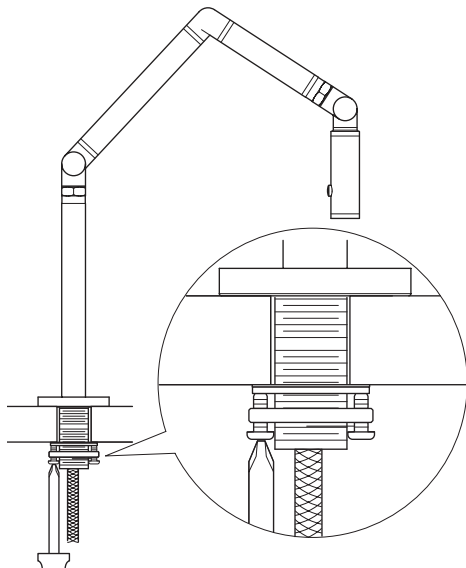

6. Turn the ring until the screws are to the front and the back. Tighten the screws securely and evenly.

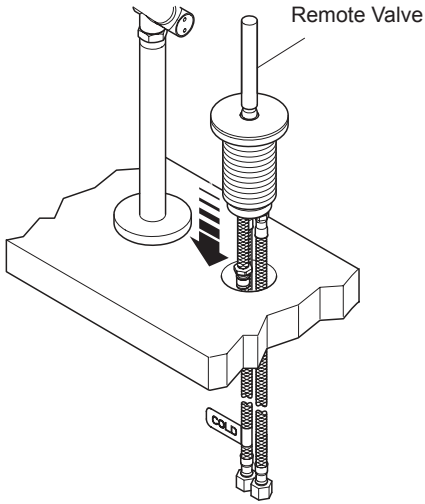

7. Apply silicone sealant to the underside of the remote valve.

Install the remote valve through the hole in the countertop.

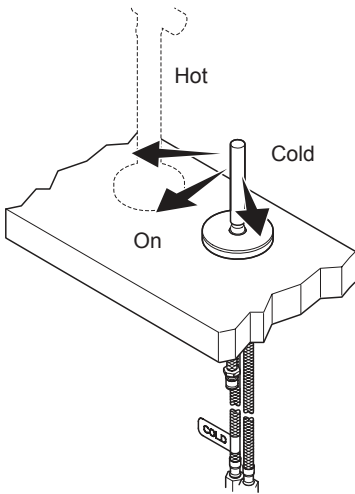

8. Before tightening the remote valve, make sure that the cold water supply is on the left hand side.

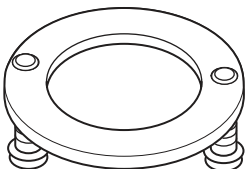

9. Partially thread the screws into the ring.

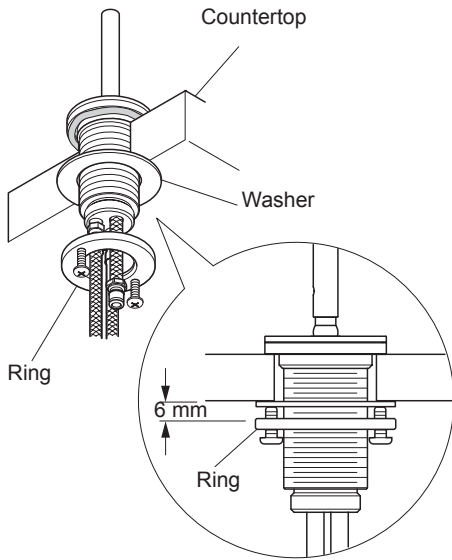

10. Slide the washer onto the remote valve threaded shank. Install the ring leaving approximately 6 mm between the ring and the countertop.

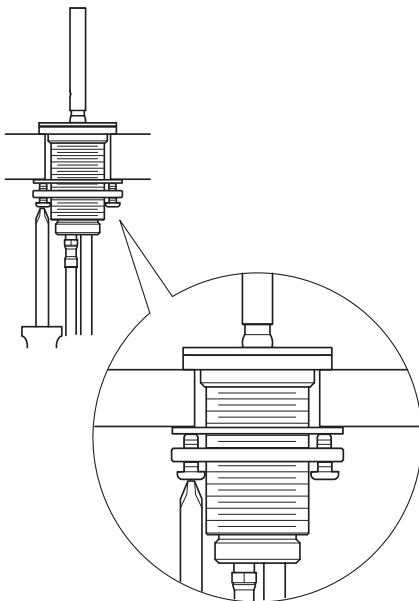

11. Turn the ring until the screws are to the front and the back. Tighten the screws securely and evenly.

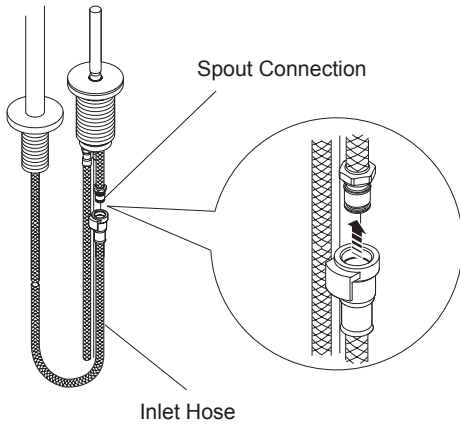

12. Connect the inlet hose to the spout connection.

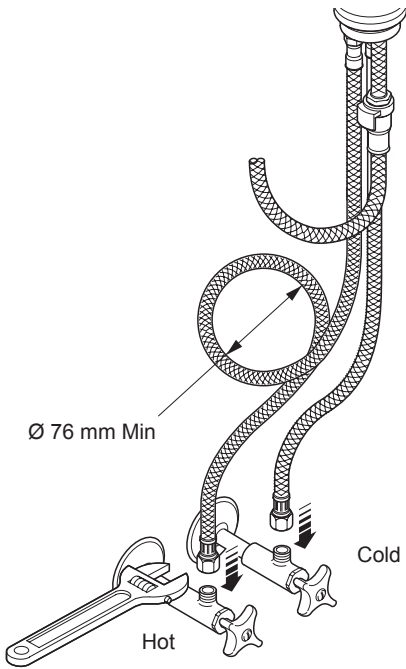

13. Connect and tighten the supply hoses.

Note! If the sink installation requires that you coil the supply hoses, maintain a 76 mm diameter inside the coil.

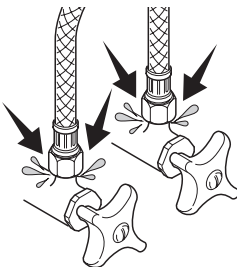

14. Check for leaks.

15. Remove the aerator.

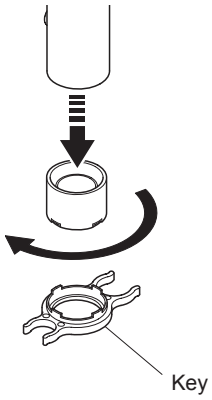

16. Flush the lines.

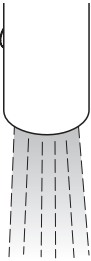

17. Reinstall the aerator.

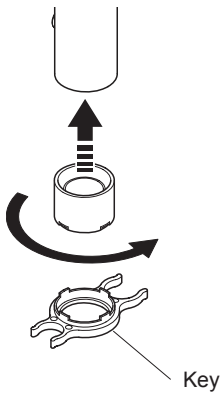

SPARE PARTS

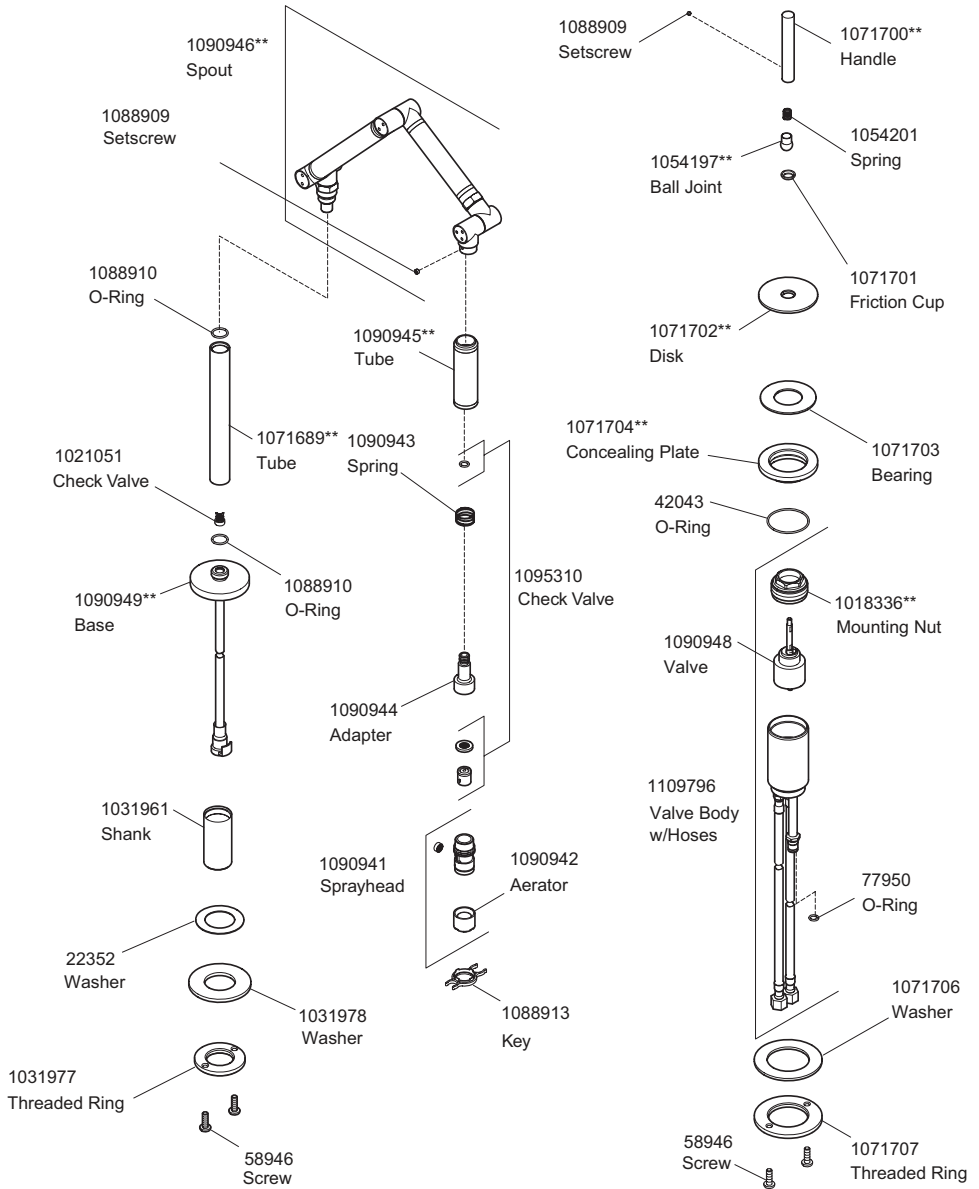

**Finish/color code must be specified when ordering

DIMENSIONS

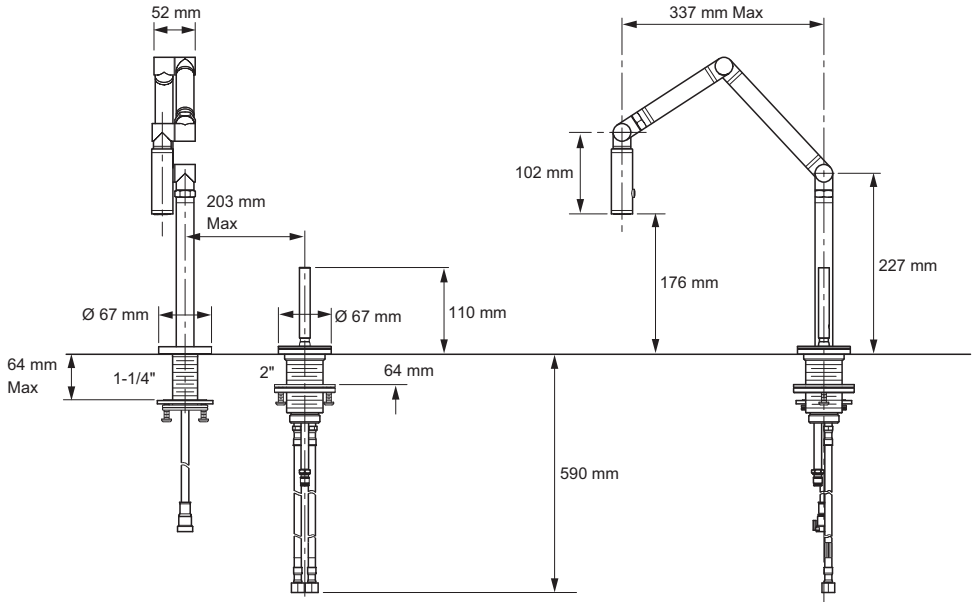

All dimensions in mm

CARE AND CLEANING

Like anything of lasting quality, Kohler tapware and fittings require a certain amount of periodic care to preserve their lustrous finish. Clean your new Kohler tapware and fittings with a mild soap, rinse thoroughly with warm water and dry with a clean, soft cloth. The ideal cleaning technique is to always blot dry any water from metal surfaces.

Allowing water to evaporate on metal will form water deposits. It is important to use a dabbing action to dry metal, not an abrasive or rubbing action.

Never use cleaners containing abrasive cleansers, ammonia, bleach, acids, or chemicals that can damage the finish. By taking the time to dry your tapware often, soap and water deposits can be prevented.

Failure to comply with these cleaning instructions may void Kohler's warranty obligations.

CUSTOMER CARE

Kohler Co. warrants its tapware manufactured after January 1, 2006, to be leak and drip free during normal residential use for as long as the original consumer purchaser owns his/her home. *If the tapware should leak or drip during normal use, Kohler will, free of charge, mail to the purchaser the cartridge necessary to put the tapware in good working condition.

Kohler also warrants all other aspects of the tapware, to be free of defects in material and workmanship during normal residential use for as long as the original consumer purchaser owns his/her own home. If a defect is found in normal residential use, Kohler Co. will, at its election, repair, provide a replacement part or product, or make appropriate adjustment. Damage to a product caused by accident, misuse, or abuse is not covered by this warranty. Proof of purchase (original sales receipt) must be provided to Kohler with all warranty claims. Kohler Co. is not responsible for labour charges, installation, or other consequential costs. In no event shall the liability of Kohler exceed the purchase price of the tapware.

If the tapware is used commercially, Kohler warrants the tapware to be free from defects in material and workmanship for one (1) year from the date the product is installed, with all other terms of this warranty applying except duration.

If you believe that you have a warranty claim, contact Kohler Co., either through your plumbing supplies retailer, or by writing.

Australian residents please contact: Kohler Co., Attn.: Customer Service Department,
PO Box 257, Regents Park, NSW 2143.

New Zealand residents please contact Kohler Co., Attn.: Customer Service Department,
133 Diana Drive, Glenfield, Auckland.

Please be sure to provide all pertinent information regarding your claim, including a complete description of the problem, the product, model number, colour, the date the product was purchased and from whom the product was purchased. Also include your original invoice. For other information, or to obtain the name and address of the service and repair facility nearest you, call 1300 362 284 from within Australia or (09) 980 6800 from within New Zealand.

The foregoing warranties are in lieu of all other warranties, express or implied, including but not limited to the implied warranties of merchantability and fitness for a particular purpose.

Seller disclaims any liability for special, incidental or consequential damages.

This warranty is to the original consumer purchaser only, and excludes product damage due to installation error, product abuse, or product misuse, whether performed by a contractor, service company, or the consumer. This is our exclusive written warranty.